

**Part Number: PT922-21110**

**Kit Contents**

Item #	Quantity Req'd.	Description
1	1	ECU
2	1	ECU Bracket
3	1	Switch
4	1	Main Harness
5	1	Switch Harness
6	1	Switch Header
6	1	Hardware Bag

**Hardware Bag Contents**

Item #	Quantity Req'd.	Description
1	2	10cm wire ties
2	14	15cm wire ties
3	35	25cm Wire ties
4	1	Large Foam tape
5	7	Medium Small Foam tape
6	5	Small Foam tape
7	4	T-taps (18-22 gauge)

**Additional Items Required For Installation**

Item #	Quantity Req'd.	Description
1	1	For interior light kit installation, PT922-21111
2	1	For illuminated door sill installation, PT922-21112

**Conflicts**

Interior light Kit PT922-21111 cannot be installed on manual transmission vehicles.

**Recommended Tools**

<b>Personal &amp; Vehicle Protection</b>	<b>Notes</b>
Safety Glasses	
Safety Gloves	Optional
Vehicle Protection	Blankets, Part Boxes
<b>Special Tools</b>	<b>Notes</b>
Nylon Panel Removal Tool	
<b>Installation Tools</b>	<b>Notes</b>
Center punch	
Drill	1/8" & 5/16" bit
Hole de-burring tool	Small round file can be used.
Screw Driver	Phillips head
Socket	10mm, 12mm
Socket wrench	
Socket extension	6"
Pliers	
Side Cutter	
Torque Wrench	4.1 N-m(36 in-lbf) 27 N-m(20 ft-lbf)
Scissors	

<b>Special Chemicals</b>	<b>Notes</b>
All Purpose Cleaner	VDC approved

**General Applicability**

All 2011 Scion tC Vehicles

**Recommended Sequence of Application**







Item #	Accessory
1	Security & RES
2*	Interior Light Controller Kit
3	Interior Light Kit/Illuminated Door Sills
4	Bluetooth
5	Audio
6	Shift knob

**\*Mandatory**

**Vehicle Service Parts** (may be required for reassembly)

Item #	Quantity Req'd.	Description
1	N/A	
2		
3		

**Legend**

	<b>STOP:</b> Damage to the vehicle may occur. Do not proceed until process has been complied with.
	<b>OPERATOR SAFETY:</b> Use caution to avoid risk of injury.
	<b>CAUTION:</b> A process that must be carefully observed in order to reduce the risk of damage to the accessory/vehicle and to ensure a quality installation.
	<b>TOOLS &amp; EQUIPMENT:</b> Used in Figures calls out the specific tools and equipment recommended for this process.
	<b>REVISION MARK:</b> This mark highlights a change in installation with respect to previous issue.
	<b>SAFETY TORQUE:</b> This mark indicates that torque is related to safety.

Care must be taken when installing this accessory to ensure damage does not occur to the vehicle. The installation of this accessory should follow approved guidelines to ensure a quality installation.

These guidelines can be found in the "Accessory Installation Practices" document.

This document covers such items as:-

- Vehicle Protection (use of covers and blankets, cleaning chemicals, etc.).
- Safety (eye protection, rechecking torque procedure, etc.).
- Vehicle Disassembly/Reassembly (panel removal, part storage, etc.).
- Electrical Component Disassembly/Reassembly (battery disconnection, connector removal, etc.).

Please see your Scion dealer for a copy of this document.

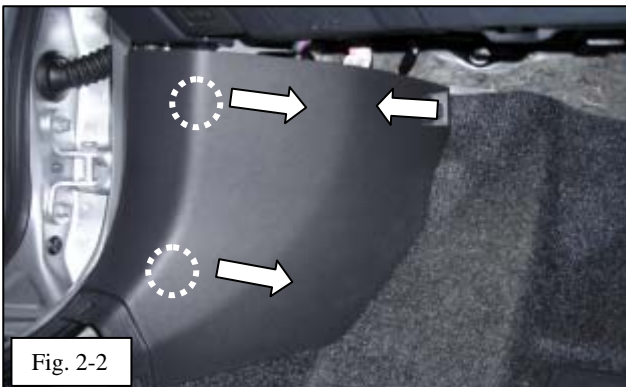
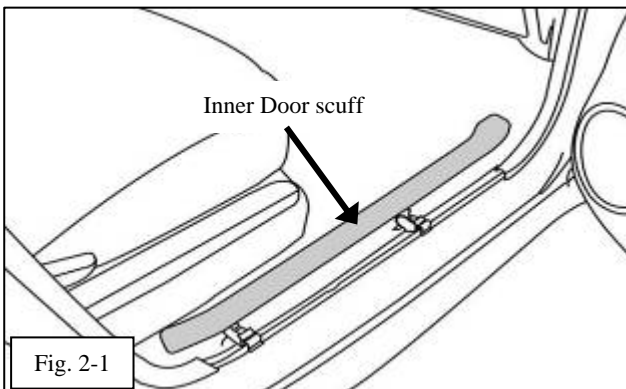

## 1. Preparation



(a) **NOTE: THIS KIT IS TO BE USED WITH INTERIOR LIGHT KIT PT922-21111 OR ILLUMINATED DOOR SILLS KIT PT922-21112 OR BOTH TO FUNCTION PROPERLY.**

(b) Inspect all kit components and check for damage or missing parts.

(c) Remove the negative battery terminal. (Fig. 1-1)



(1) Do not touch the positive terminal with any tool part of the tool when removing cable.

## 2. Vehicle disassembly

(a) Remove the front left and front right inner door scuff panels. (Fig. 2-1)

(b) Remove the front left and front right cowl trim panels. (Fig. 2-2)

(1) Pull the cowl panel from the retaining stud.

(2) Pull the cover straight away from the body to detach the two clips.

(3) If a clip is stuck to the body after removal, remove the clip and reattach it to the cowl cover.



(c) Remove the lower IP panel. (Fig. 2-3)



(d) Remove the outside mirror switch panel.  
(Fig. 2-4)



(1) Disconnect any connectors connected to the outside mirror switch panel.



(e) Remove the upper center IP panel. (Fig. 2-5)



(1) Disconnect any connectors connected to the panel.

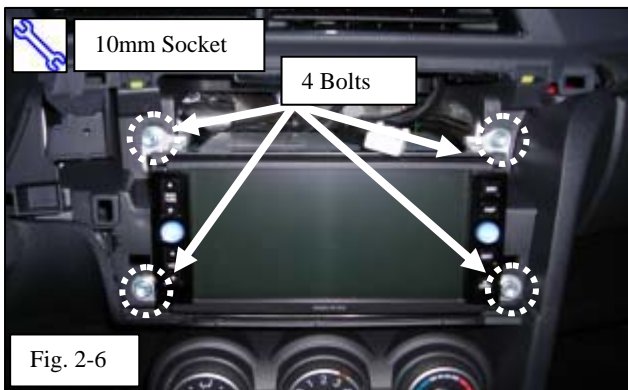

(f) Remove the audio head unit if equipped.



(1) Remove all connectors connected to the head unit. (Fig. 2-6)

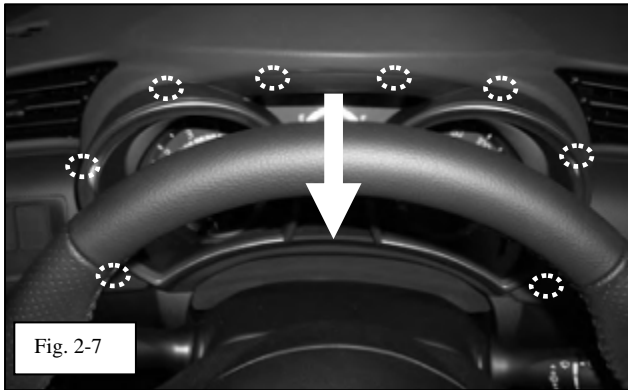

(g) Remove the combination meter assembly outer panel. (Fig. 2-7)

(1) If necessary, adjust the height of the steering wheel before removing the panel.



(2) Use caution when removing the panel to prevent scratches.

(h) Remove the combination meter assembly. (Fig. 2-8)

(1) Unscrew the Phillips head screw from the top of the meter.

(2) Pull out on the two side pull tabs "A" to remove.



**CAUTION: DO NOT PULL METER ASSEMBLY FROM ANYWHERE EXCEPT THE PULL TABS "A".**



(3) Use caution when removing the panel to prevent scratches.

(i) Remove the center console right side panel. (Fig. 2-9)

(1) Pull up on the inside left of the panel to disengage the two rear clips.

(2) Rotate the panel clockwise to the right to disengage the three front clips and remove.

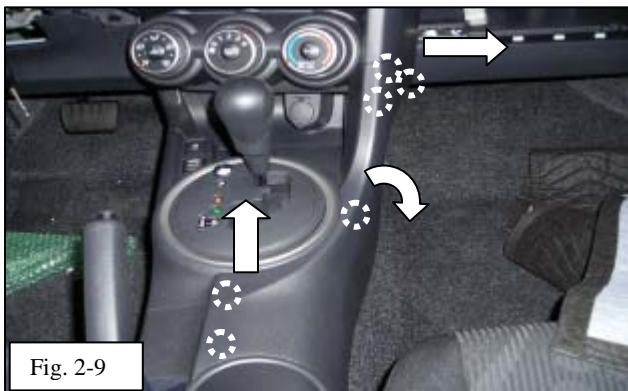
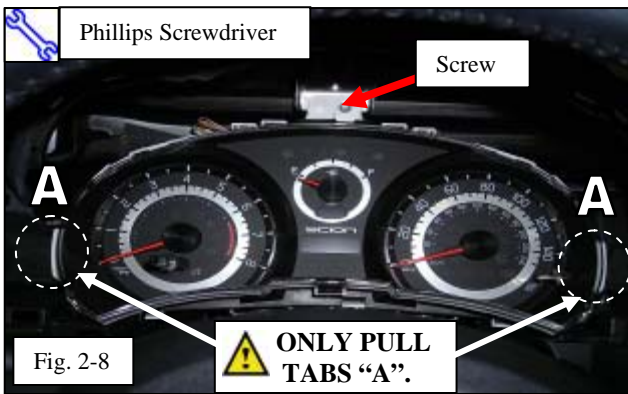

(j) Remove the center console left side panel. (Fig. 2-10)



(1) Disconnect any connectors connected to the panel.

(2) For manual transmission vehicles, undo the shift cover from the panel.





(k) Remove the cup holder panel. (Fig. 2-11)



(l) Remove the power outlet panel. (Fig. 2-12)



(1) Disconnect the power outlet connector.



(m) Remove the glove box. (Fig. 2-13)

- (1) Open the glove box.
- (2) Push inward on the glove box side panels to dislodge the glove box retainers.
- (3) Pull the glove box straight outward.



(n) Remove the back panel in the glove box area. (Fig. 2-14)



Fig. 3-1

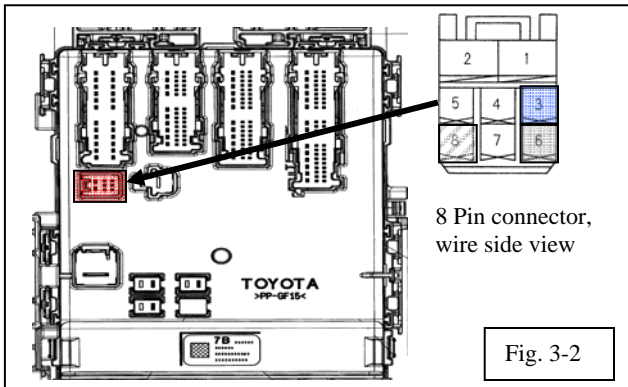

Fig. 3-2

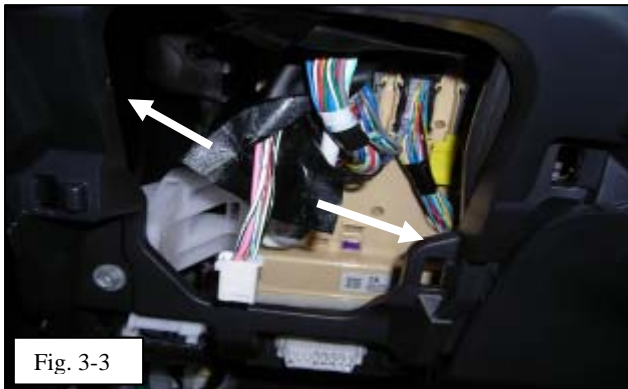

Fig. 3-3

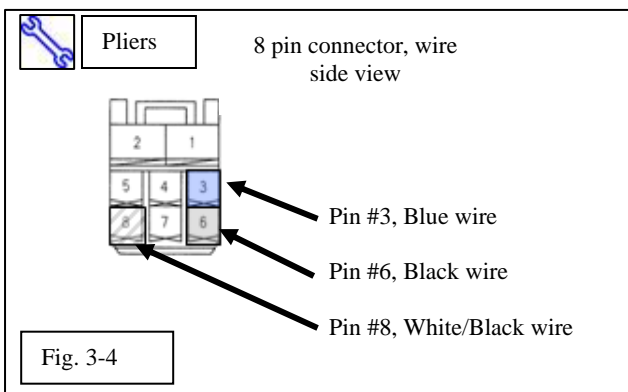

Fig. 3-4

### 3. Install T-taps

(a) Locate the junction block on the driver side lower IP area. (Fig. 3-1)

(b) Locate and disconnect the 8 pin connector on the junction block. (Fig. 3-2)

(c) Peel back part of the protective tape to expose the wires. (Fig. 3-3)

(d) Install T-Taps to the 8 pin connector. (Fig. 3-4)

(1) Apply a T-tap to the BLUE wire, PIN #3 about 1 inch away from the connector.



(2) Apply a T-tap to the WHITE/BLACK wire, PIN #8 about 1.5 inches from the connector.



(1) There is more than one WHITE/BLACK wire on the connector.

(3) Apply a T-tap to the BLACK wire, PIN #6 about 2 inches from the connector.

(4) Make sure the T-taps are snapped in correctly.

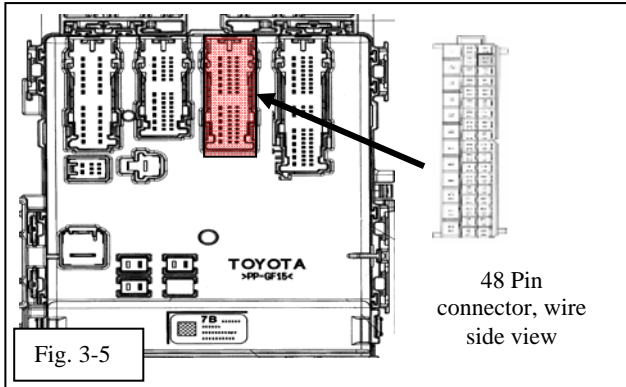

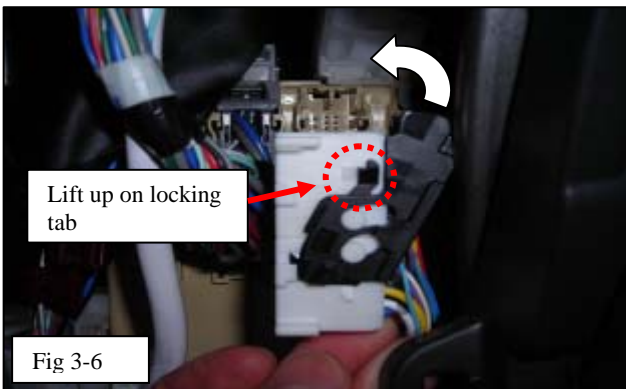

- (e) Locate and disconnect the 48 pin connector on the junction block. (Fig. 3-5)
  - (1) Press downward on the locking tab located close to the top of the connector to release the lock.
  - (2) Rotate the connector lock from the top outward.
  - (3) Gently pull the connector out.

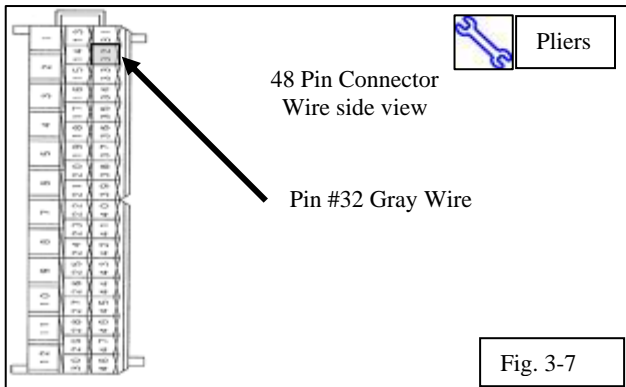

- (f) Move the connector lock to the closed position to gain better access to the wires. (Fig. 3-6)
  - (1) Lift up on the locking tabs located on both sides of the connector.
  - (2) Rotate the connector lock to the closed position.



-  (g) Apply a T-tap to the GRAY wire, PIN #32 about 1 inch away from the connector. (Fig. 3-7)

-  (1) There is more than one GRAY wire on the connector.
- (2) Make sure the T-tap is snapped in correctly.

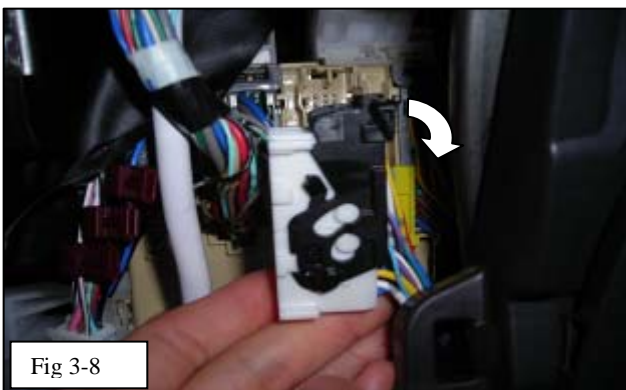

- (h) Pull the connector lock back out to the open position. (Fig. 3-8)

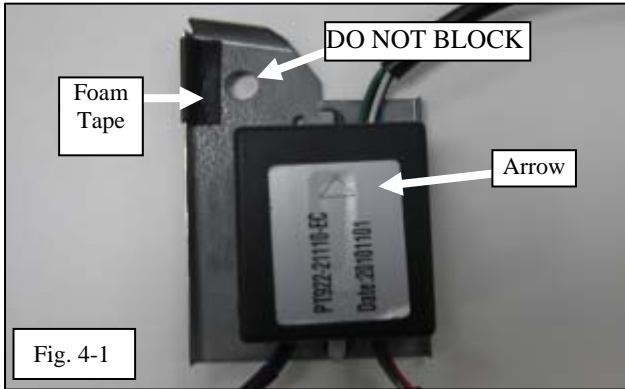

Fig. 4-1

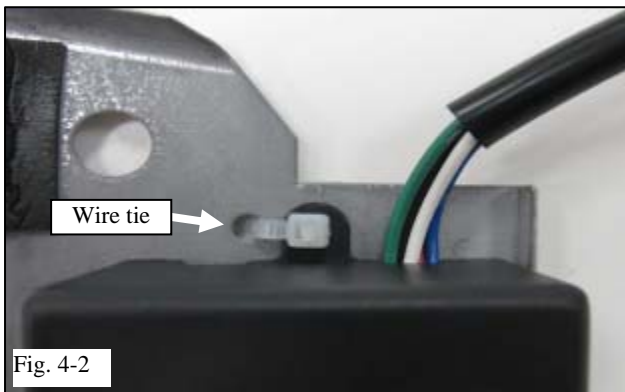

Fig. 4-2

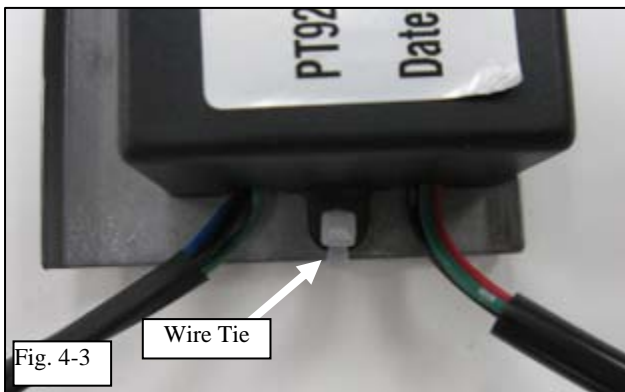

Fig. 4-3

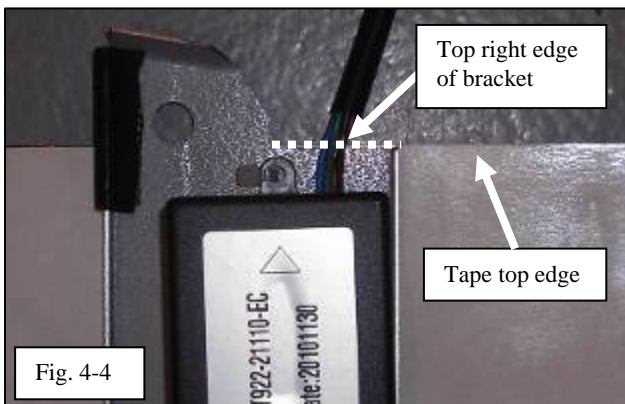

Fig. 4-4

#### 4. Install ECU

(a) Install the ECU to the bracket.

- (1) Orient the ECU so that the arrow on the label is pointing up. (Fig. 4-1)
- (2) Wrap the top left bracket edge with a small piece of foam tape. (Fig. 4-1)



- (1) DO NOT block the mounting hole with foam tape.
- (2) Trim tape as needed.
- (3) Secure the ECU to the bracket using the top two mounting holes with one (1) small wire tie as shown. (Fig. 4-2)
  - (1) Orient the wire tie so that the head is on the front side of the bracket.
- (4) Trim the wire tie.

- (5) Secure the ECU to the bracket using the bottom mounting hole with one (1) small wire tie as shown. (Fig. 4-3)

- (1) Orient the wire tie so that the head is on the front side of the bracket.
- (6) Trim the wire tie.

- (7) Align the large foam tape to the ECU so that the top edge of the tape lines up to the top right edge of the bracket. (Fig. 4-4)



- (1) DO NOT cover the top right edge of the bracket with tape.



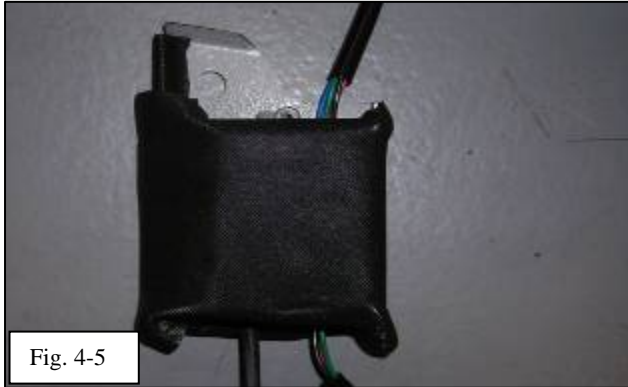

(8) Wrap the ECU and bracket with the large foam tape. (Fig. 4-5)

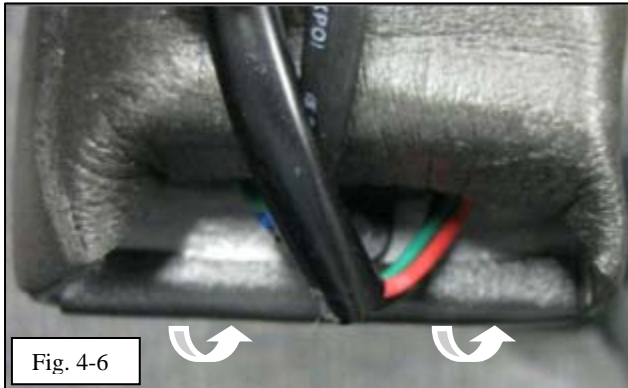

(9) Fold the excess tape from the bottom upward to cover the bottom edge. (Fig. 4-6)

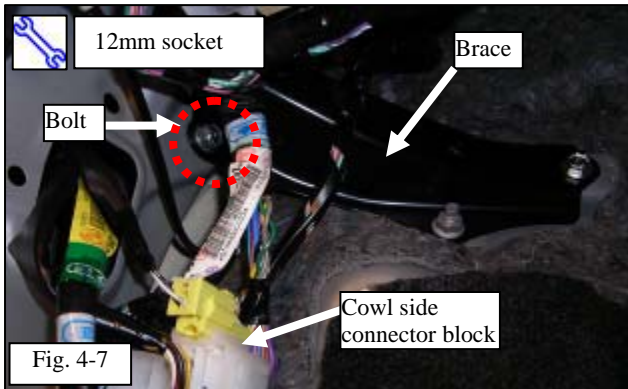

(b) Locate and remove the 8M bolt on the driver side brace using a 12mm socket wrench and extension.

(1) The brace is located behind the fuse block and above the cowl side connector block. (Fig. 4-7)

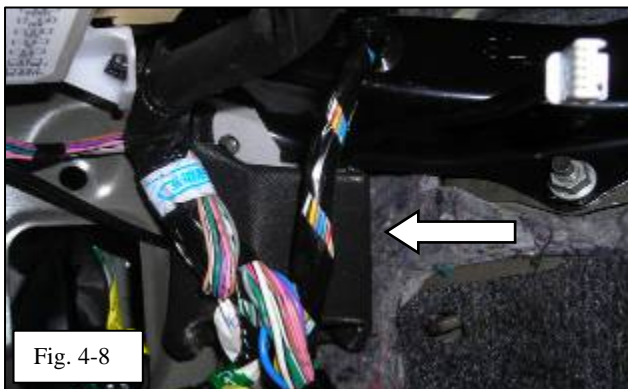

(c) Install the ECU and bracket to the brace.

(1) Slide the ECU between the OE harnesses and the carpet. (Fig 4-8)

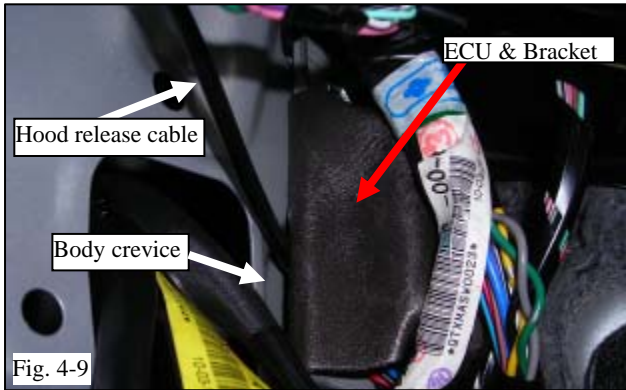

(2) Position the bracket so that the hood release cable is behind the bracket. The cable should be placed such that it sits in the space between the ECU bracket and the body crevice. (Fig 4-9)

(3) The bracket hole should line up to the hole on the brace. (Fig. 4-10)



(4) The top right edge of the bracket should sit against the bottom edge of the brace. (Fig. 4-10)

(5) Secure the bracket using the M8 bolt that was removed previously. Torque to 27N-m (20 ft-lbs). (Fig. 4-10)

(1) Hold the bracket on the bottom left corner to keep it from rotating while fastening the M8 bolt.

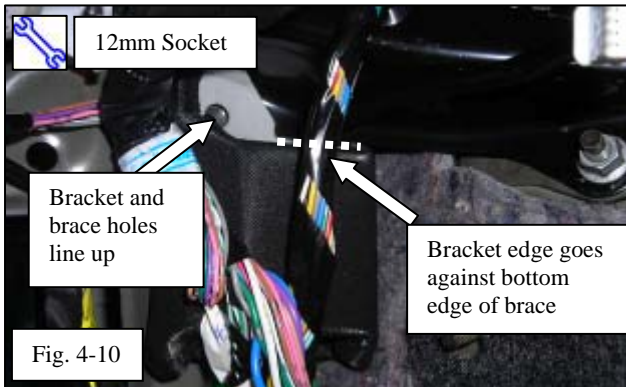

(6) Check to make sure the hood release cable is not pinched between the body and the bracket. There should be some movement behind the bracket.

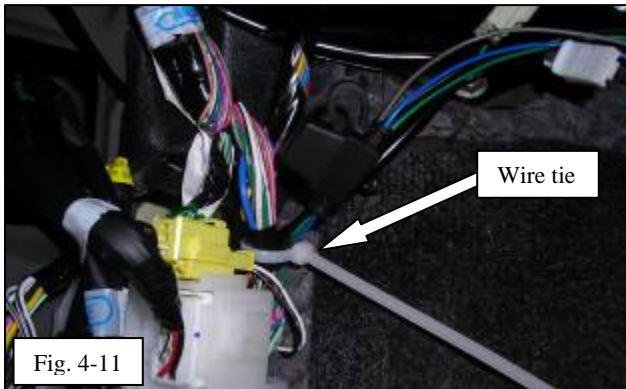

(d) Route the ECU power harness AND the 3 pin ECU switch harness behind the OE harness and to the right as shown. Secure to the OE harness with one (1) long wire tie. (Fig. 4-11)

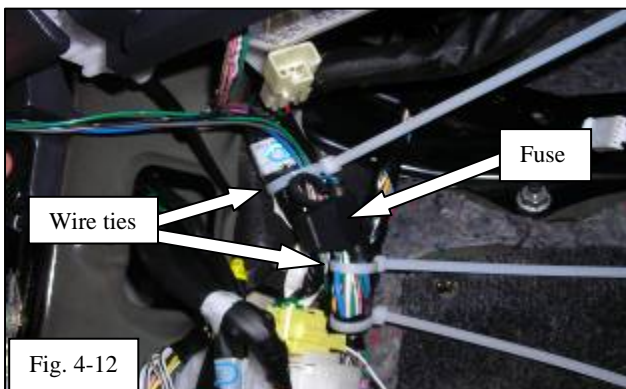

(e) Route the ECU power harness and the 3 pin ECU switch harness up the OE harness and secure to the OE harness with two (2) long wire ties as shown. (Fig. 4-12)

(1) The fuse should be secured between the two wire ties.

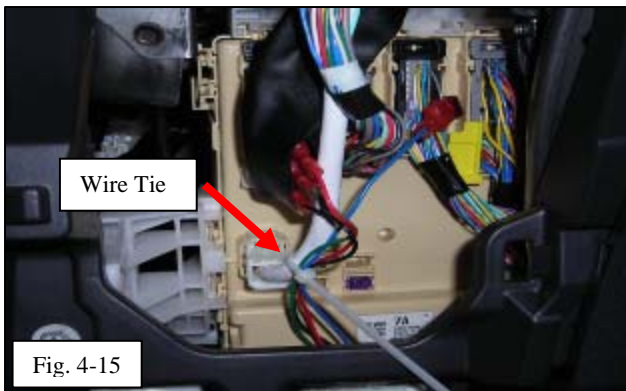
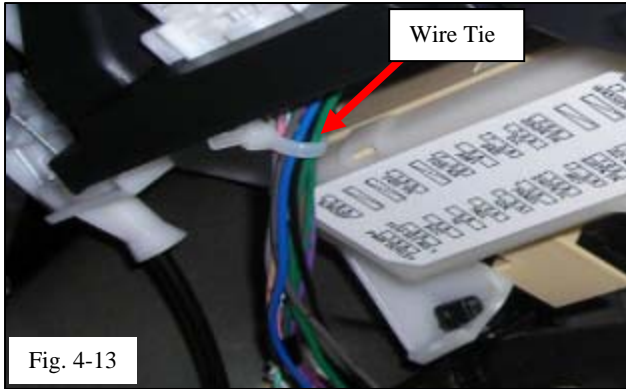

- (f) Route the ECU power harness to the junction block area as shown. Secure the harness to the OE harness with one (1) long wire tie. (Fig 4-13)
- (g) Connect the power and signal wires to the T-taps on the junction block. (Fig. 4-14)
  - (1) Connect the Gray wire to the T-tap on the Gray wire located on the 48 pin connector.
  - (2) Connect the Blue wire to the T-tap on the Blue wire located on the 8 pin connector.
  - (3) Connect the Black wire to the T-tap on the Black wire located on the 8 pin connector.
  - (4) Connect the Green wire to the T-tap on the White/Black wire located on the 8 pin connector.
- (h) Re-apply the protective tape around the harness and the T-taps.
- (i) Reinstall the 8 pin connector
- (j) Reinstall the 48 pin connector.
  - ⚠ (1) Make sure the connector lock is in the open position before installing to the junction block.
  - ⚠ (2) Make sure the connector is properly aligned to the junction block before pressing the connector in.
  - ⚠ (3) Make sure the connector is locked into place when installed.
- (k) Secure the ECU power harness to the OE wire harness with one (1) long wire tie as shown. (Fig. 4-15)
- (l) Trim the excess off the wire ties.



Fig. 5-1

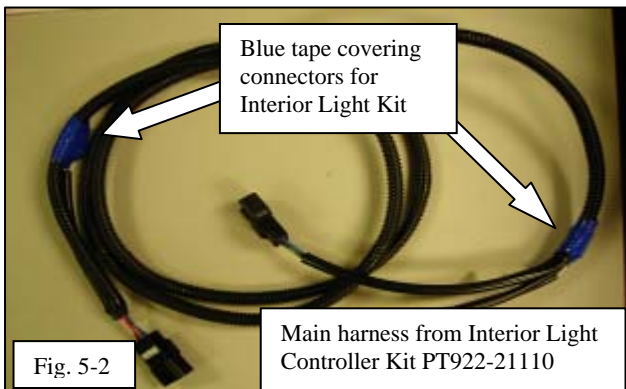

Fig. 5-2

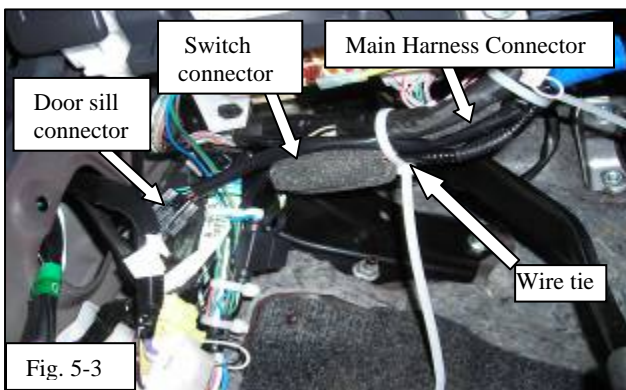
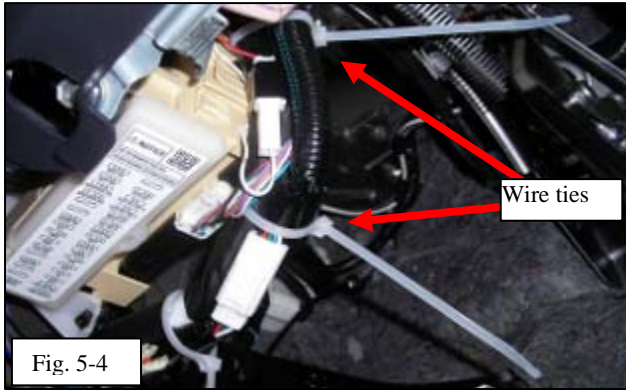

Fig. 5-3

**5. Route Main Harness and Switch Harness to head unit opening**

- (a) Please see Fig 5-1 for overall wire harness route.
- (b) **If installing the Interior Light Kit (PT922-21111)**, remove blue electrical tape on the main harness to access the two interior light kit connectors. (Fig. 5-2)
  - (1) DO NOT perform this step if only installing illuminated door sills.
- (c) Connect the Main harness 5 pin connector to the 5 pin connector on the ECU harness. Wrap the connector with medium foam tape.
- (d) Connect the 3 pin Switch harness connector to the 3 pin connector on the ECU harness. Wrap the connector with medium foam tape.
- (e) Secure the Main harness, the Switch harness, the illuminated door sill harness, and the interior light kit harness to the OE harness as shown with one (1) long wire ties. (Fig. 5-3)



(1) The secured harnesses and connectors should sit toward the back side of the OE harness.

(f) Route the harness along the OE harness to the right side of and upward behind the fuse block. Secure with two (2) long wire ties as shown. (Fig. 5-4)

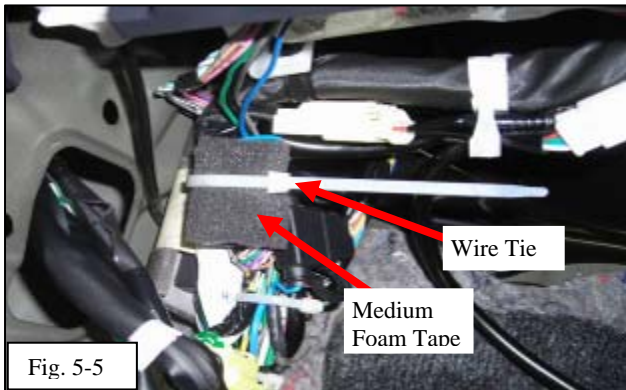

(g) Wrap the Driver side Illuminated door sill connector with medium foam tape and secure to the OE harness above the connector block with one (1) long wire tie as shown. (Fig 5-5)



(1) Make sure the foam tape does not cover the connector opening.

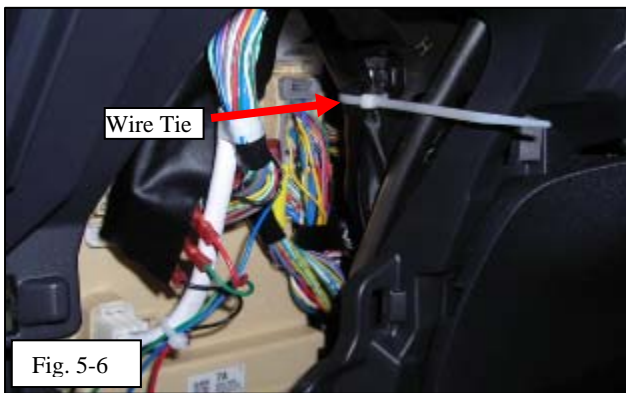

(h) Route the Main harness and Switch harness along the OE harness to the front of the junction block area. Secure the Main harness and Switch harness to the OE harness as shown with one (1) long wire tie. (Fig. 5-6)

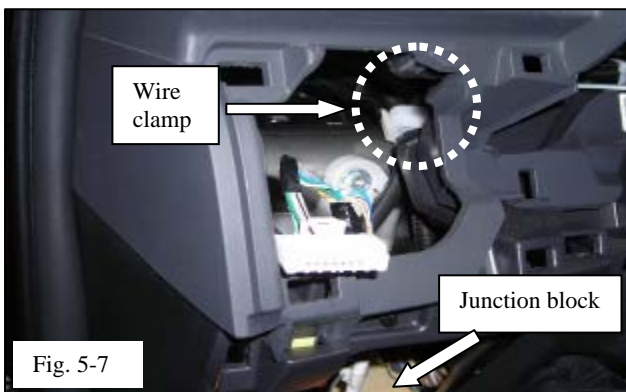

(i) Continue to route both harnesses toward the power mirror switch opening.

(j) Open the wire clamp and secure the main harness and the switch harness to the wire clamp. (Fig. 5-7)

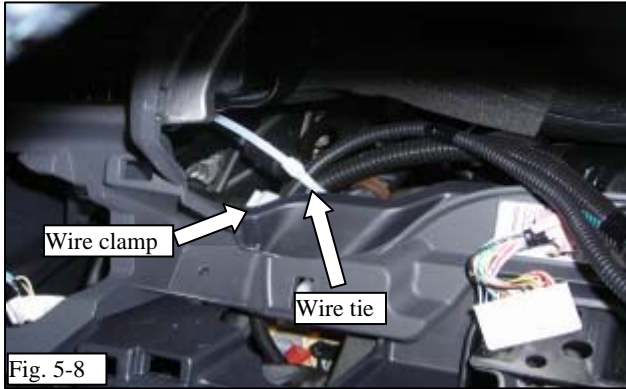

- (k) Secure the switch harness and the main harness to the OE harness after the wire clamp with one (1) long wire tie as shown. (Fig. 5-8)

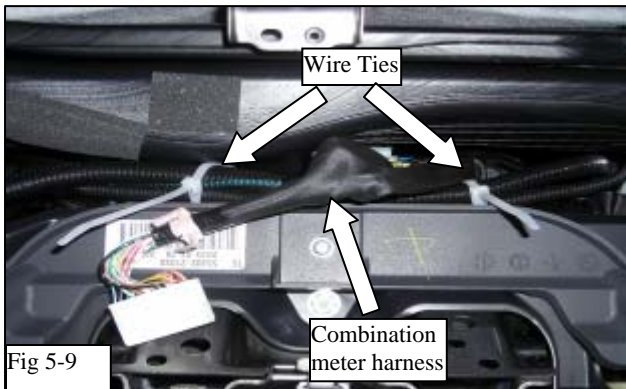

- (l) Route both harnesses across the combination meter opening and secure with two (2) long wire ties as shown. (Fig. 5-9)



- (1) DO NOT secure to the combination meter harness. If necessary, move the combination meter harness out of the way before applying wire ties.

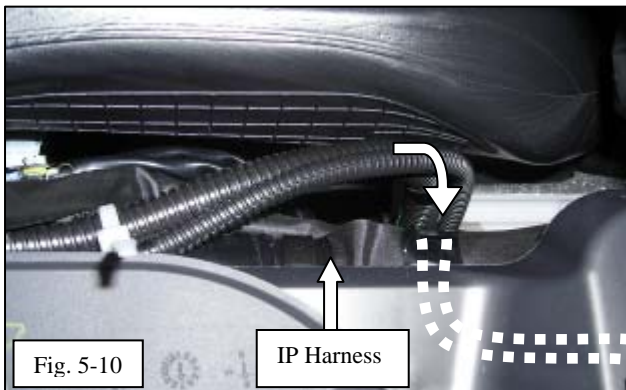

- (m) Route both harnesses over the IP harness, behind the support bar, and toward the head unit opening. (Fig. 5-10 & 5-11)

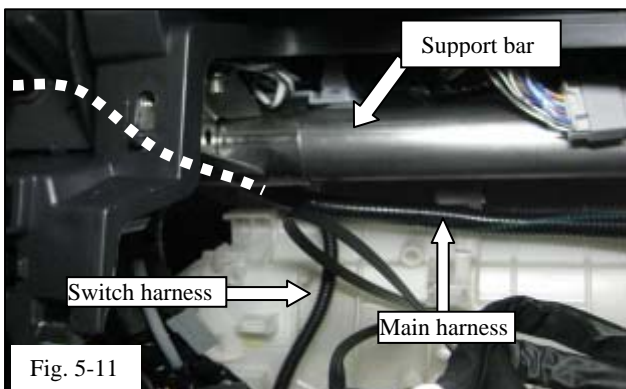

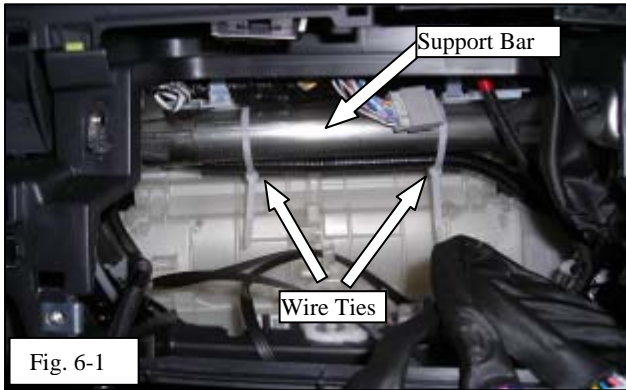

**6. Route Main harness from head unit opening**

- (a) Route the Main harness along the bottom of the support bar through the head unit opening towards the glove box opening.
- (b) Secure the Main harness to the support bar using two (2) long wire ties as shown. (Fig. 6-1)

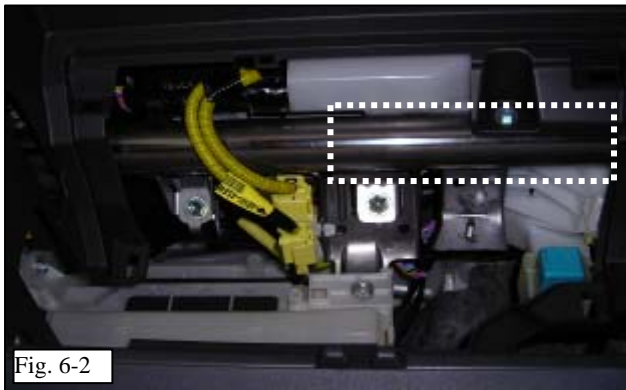

- (c) Clean the support bar in the glove box area with an approved cleaner in the area as shown. (Fig. 6-2)



- (1) Make sure the bar is cleaned well so that tape can be adhered to it properly.

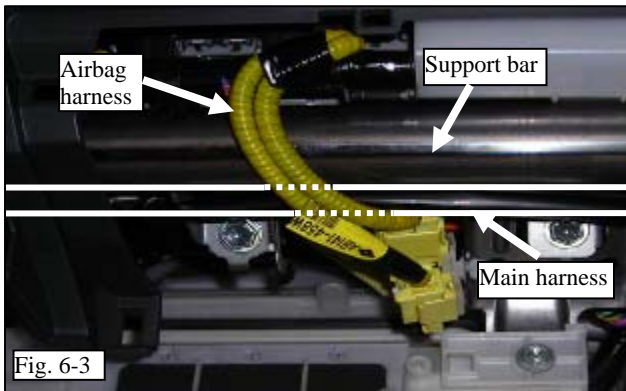

- (d) Route the Main harness along the bottom of the support bar into the glove box opening. (Fig. 6-3)



- (1) Make sure the Main harness is routed between the support bar and the airbag harness.



- (2) Make sure the harness is routed so that it does not interfere with the air bag harness.

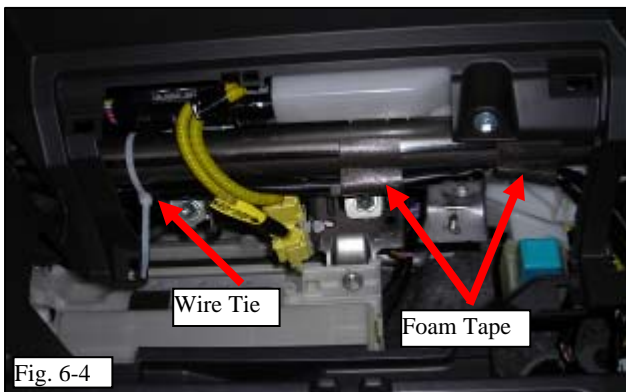

- (e) Secure the Main harness to the support bar using one (1) long wire tie and two (2) pieces of medium foam tape as shown. (Fig. 6-4)



- (f) Route the Main harness along the support bar to the right of the relay and secure with one (1) long wire tie to the support bar. (Fig 6-5)

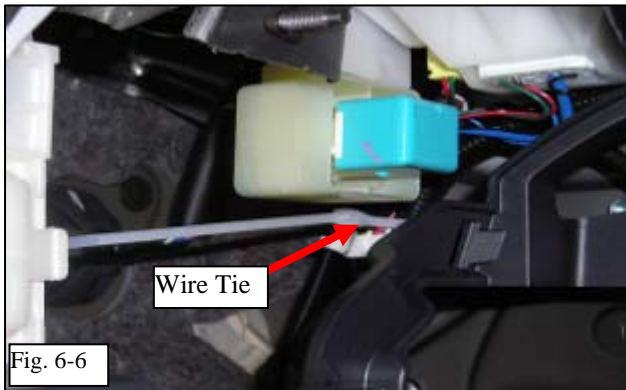

- (g) Continue to run along the OE harness down to the passenger side foot well area and secure with one (1) long wire tie as shown (Fig. 6-6)

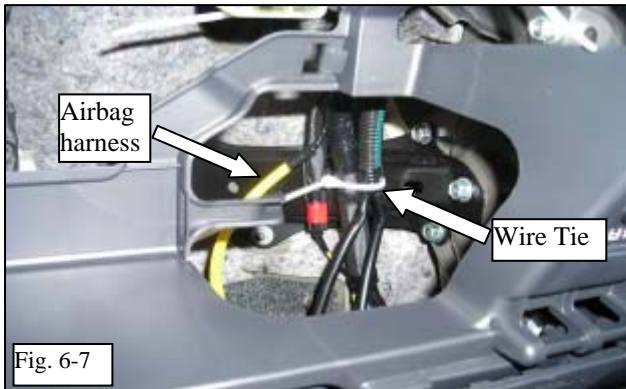

- (h) Secure the Main harness to the OE harness with one (1) long wire tie as shown. (Fig. 6-7)



- (1) DO NOT secure to the yellow airbag harness.



- (i) Wrap the Driver side Illuminated door sill connector with medium foam tape and secure to the OE harness with one (1) long wire tie as shown. (Fig 6-8)



- (1) DO NOT secure to the yellow airbag harness.



- (2) Make sure the foam tape does not cover the connector opening.





**7. Route Switch harness from head unit opening**

(a) Route the switch harness down behind the heater controls toward the center console. (Fig. 7-1)

(1) The wire should be routed along the OE harness to the left of the shifter towards the cup holder opening.

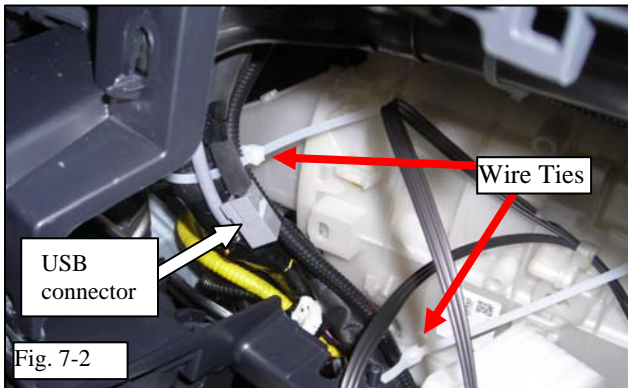

(b) Secure the Switch harness to the OE harness in the area located on the left side of the head unit opening with two (2) long wire ties. (Fig 7-2)



(1) Avoid putting a wire tie around the USB harness.

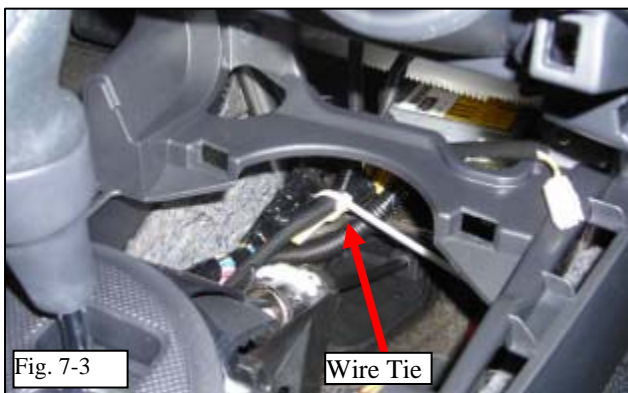

(c) Route the Switch harness down in front of the shifter and secure with one (1) long wire tie. (Fig. 7-3)

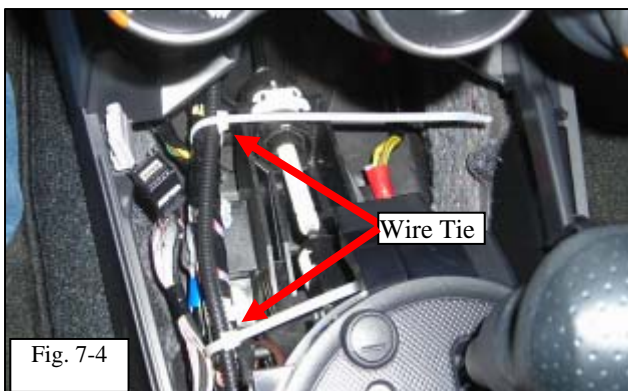

(d) Continue to route the harness along the OE harness to the left of the shifter towards the cup holder opening.

(e) Secure the harness to the OE harness in the shift area opening as shown with two (2) long wire ties. (Fig. 7-4)



(f) Detach Velcro and fold to the side. (Fig. 7-5)

(g) Continue to route the harness to the cup holder opening along the OE harness.



(1) Make sure the harness goes under the shifter panel.

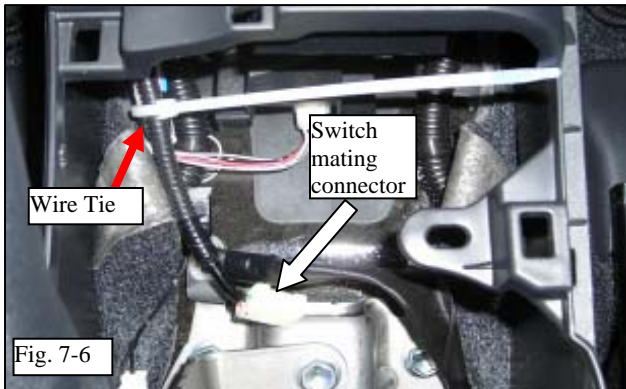

(h) Secure the harness to the OE harness in the cup holder area opening as shown with one (1) wire tie. (Fig. 7-6)

(1) The connector should sit around the center of the opening next to the OE harness.

(i) Reattach Velcro.

## 8. Paper Templates

(a) Cut out installation templates located on the last page of the installation instructions.

(1) Check the two inch reference on the paper templates to make sure the templates are printed to the correct scale.

(2) Using scissors, cut out the paper templates.

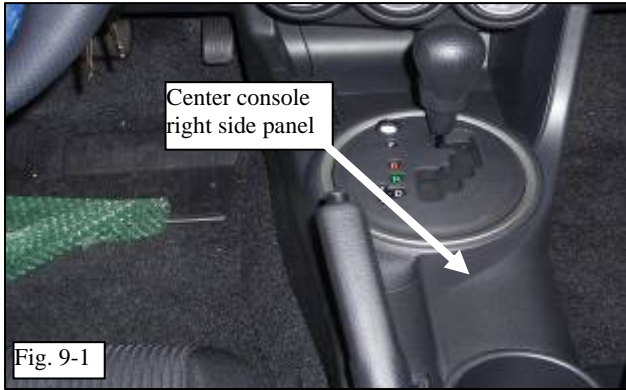

### 9. Install Switch

- (a) Locate the center console right side panel that was removed during disassembly. (Fig. 9-1)
  - (b) Place the drill template onto the back side of the panel below the two clips. (Fig. 9-2)
    - (1) Align the edges of the template to the ribs on the back side of the panel.
    - (2) Apply tape to keep template in place.
  - (c) Use a center punch to mark the center of the hole on the panel and remove the template.
  - (d) Drill a pilot hole through the center mark using a 1/8" drill bit.
  - (e) Drill through the 1/8" hole with a 5/16" drill bit to enlarge the hole.
  - (f) Using a de-burring tool, lightly remove any excess material and clean the hole so there are no sharp edges.
  - (g) Using an approved cleaner, clean the top surface of the center console right side panel.
  - (h) Place the switch alignment template onto the panel and tape it in place. (Fig. 9-3)
    - (1) The top part of the template should fit below the top curve of the panel.
    - (2) The left side of the template should follow the edge of the plastic parting line.
    - (3) The bottom curve of the template should follow the bottom curve of the panel.
- 
- (4) Make sure the tape does not cover the area where the switch will be installed.

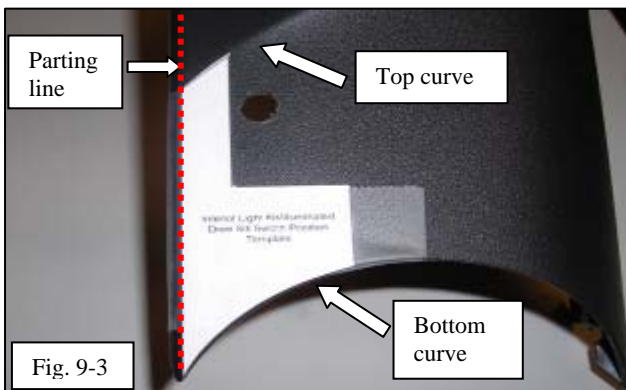
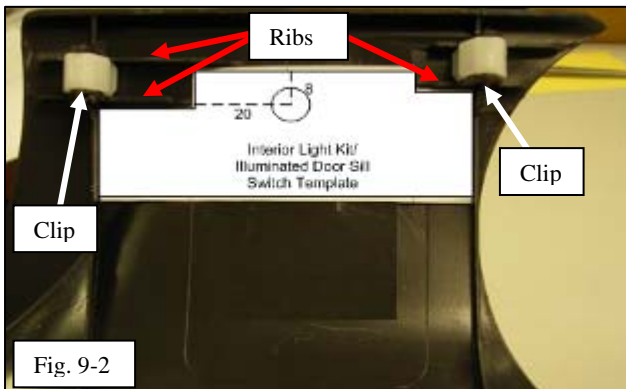

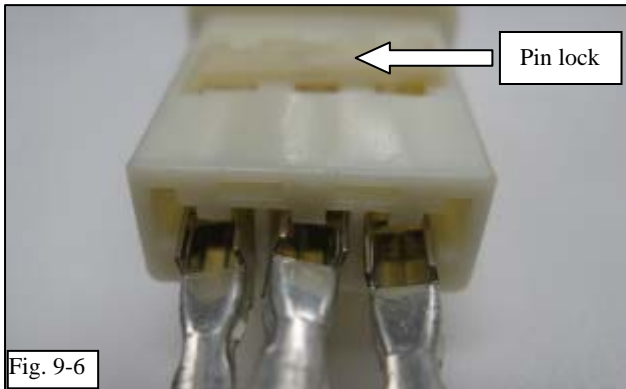
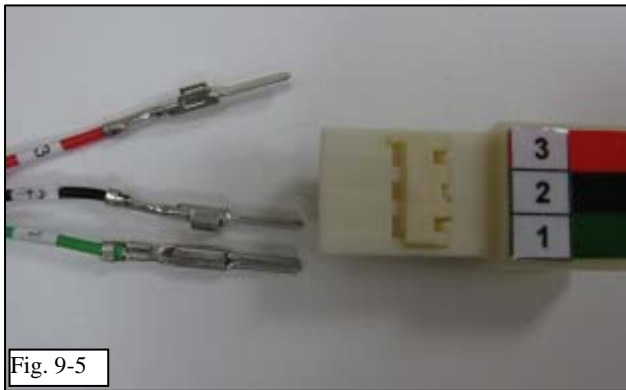

- (i) Install the Switch.
  - (1) Insert the wires from the switch through the hole.
  - (2) Orient the switch so that the word “Illumination” Can be read right side up from the driver’s seat. (Fig. 9-4)
  - (3) Peel off the tape from the back of the switch and install the switch using the locating template edges. (Fig. 9-4)
  - (4) Remove the template.

- (j) Attach the switch wires to the switch connector.



(1) Putting pins into to the incorrect locations can cause damage to the ECU.



(2) The wire colors and numbers should match the color and number of the connector slots. (Red(3) to Red(3), Black(2) to Black(2), Green(1) to Green(1)). (Fig. 9-5)

(3) Position the pins in the proper orientation before inserting into the connector. (Fig. 9-6)

(4) Fully insert the pins in to the connector and press down on the connector terminal lock to lock in the pins.

(5) Check each wire after inserting to make sure the terminals are locked in properly.

- (k) Connect switch connector to the switch harness connector located in the cup holder opening. (Fig. 9-7)

(1) Wrap the connectors with one (1) piece of medium foam tape.

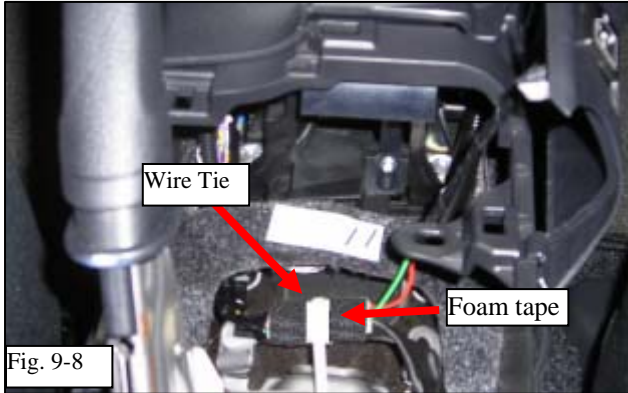

- (2) Secure the connector to the OE harness with one (1) long wire tie. (Fig. 9-8)
- (3) Temporarily reinstall the right side panel so that it is in the open position.

**10. Install Interior Light Kit**

- (a) Please see installation instructions for PT922-21111 if installing interior light kit.

**11. Install Illuminated Door Sill**

- (a) Please see installation instructions for PT922-21112 if installing illuminated door sills.

**12. Testing**

- (a) Temporarily reinstall the negative battery terminal.
- (b) If required, install the short pin located in the engine compartment fuse box.
- (c) Perform accessory function check.

- (1) Open a door. The interior light kit or illuminated door sills should light up. The switch LED should be ON.
- (2) With a door open, press the illumination switch to cycle through all 7 of the colors. (There are two blue color positions when a door is open.)

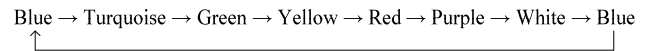

- (3) With the key in the OFF position, close all doors (including the trunk). The interior light kit or illuminated door sills should turn off. The switch LED should turn OFF.

- (4) With all doors closed, turn the key to ACC/ON position. The switch LED should come on.
- (5) With all doors closed and with the key in ACC/ON position, press the switch to cycle through all 7 of the colors and the off position.

Blue → Turquoise → Green → Yellow → Red → Purple → White → Off  
↑

- (d) Remove the negative battery terminal.

### 13. Reassembly

- (a) Trim all wire ties.
- (b) Reinstall the power outlet panel.



- (1) Make sure to reconnect the disconnected connector.

- (c) Reinstall the center console left side panel.



- (1) Make sure to reconnect the disconnected connectors.

- (d) Reinstall the cup holder panel.

- (e) Reinstall the center console right side panel.



- (1) Make sure the switch harness is not pinched.

- (f) Reinstall the glove box back panel and the glove box.

- (g) Reinstall the combination meter.



- (1) Make sure to reconnect the disconnected connector.

- (h) Reinstall the combination meter cover.



- (1) Make sure to seat the upper clips to the upper IP panel before engaging all clips.

(i) Reinstall the power outside mirror switch panel.



(1) Make sure to reconnect the disconnected connectors.

(j) Reinstall the lower IP panel.

(k) Reinstall the driver and passenger side cowl panel.

(l) Reinstall the driver and passenger side door scuff.

(m) Reinstall the head unit if equipped.



(1) Make sure to reconnect any disconnected connectors.

(n) Reinstall the center IP panel.



(1) Make sure to reconnect the disconnected connector.

(o) Check all panels for proper fit.

#### 14. Completing the installation.

(a) Reinstall the negative battery terminal.

(1) Position the negative battery cable at the original factory position.

(2) Tighten the nut with 4.1 N-m (36 lbf-in) of torque.



(3) Do not touch the positive battery terminal with any tool when replacing the cable.

(b) If required, replace the short pin to its original position.

(c) Place operation instruction card into glove box.

(d) Perform vehicle function checks.

(e) Clean up and remove any trash.

Checklist - these points **MUST** be checked to ensure a quality installation.

Check:

Look For:

Accessory Function Checks

- Open a door
- Close doors with key in OFF position.
- Close doors with key in ACC/ON position
- Switch LED
- Color selection

Interior light kit or illuminated door sills should be ON.

Interior light kit or illuminated door sills should turn off within a few seconds.

Interior light kit should remain on (except if color selection is in the off position)

Switch LED should be ON when a door is open or when key is in ACC/ON position.

Color should be selectable when switch LED is illuminated.

Vehicle Function Checks

- USB jack
- VSC/Traction control button
- 12V Power outlet
- Combination meter
- Power outside mirrors
- Hazard lights
- Clock display
- Audio system
- Dome lights
- Sunroof

USB jack should function normally.

VSC/Traction control should function normally.

Power outlet should function properly.

Combination meter gauges, lights, and illumination should function properly.

Power outside mirrors should function normally.

Hazard lights should function properly.

Clock should work properly.

Audio system should function properly.

Dome lights should operate normally.

Sunroof should operate normally.



Checklist - these points **MUST** be checked to ensure a quality installation.

Check:

Look For:

- Power door locks
- Power windows
- Rear defogger
- Tail lamps
- Security System (If equipped)
- Fog Lights (If equipped)
- Bluetooth (If equipped)
- Hood latch cable

Power door locks should function normally.

Power windows should function normally.

Rear defogger should function properly.

Tail lamps should function properly.

Security system should operate normally.

Fog lights should function properly.

Bluetooth should function properly.

Hood should pop open and close properly.

Vehicle Appearance Check

- After accessory installation and removal of protective cover(s), perform a visual inspection.

Ensure no damage (including scuffs and scratches) was caused during the installation process.

(For PPO installations, refer to TMS Accessory Quality Shipping Standard.)

Note: Cut outside solid lines

